

Pressure-regulator of the Standard series

Pressure regulator G2 pneumatic pilot operated (G1/4)

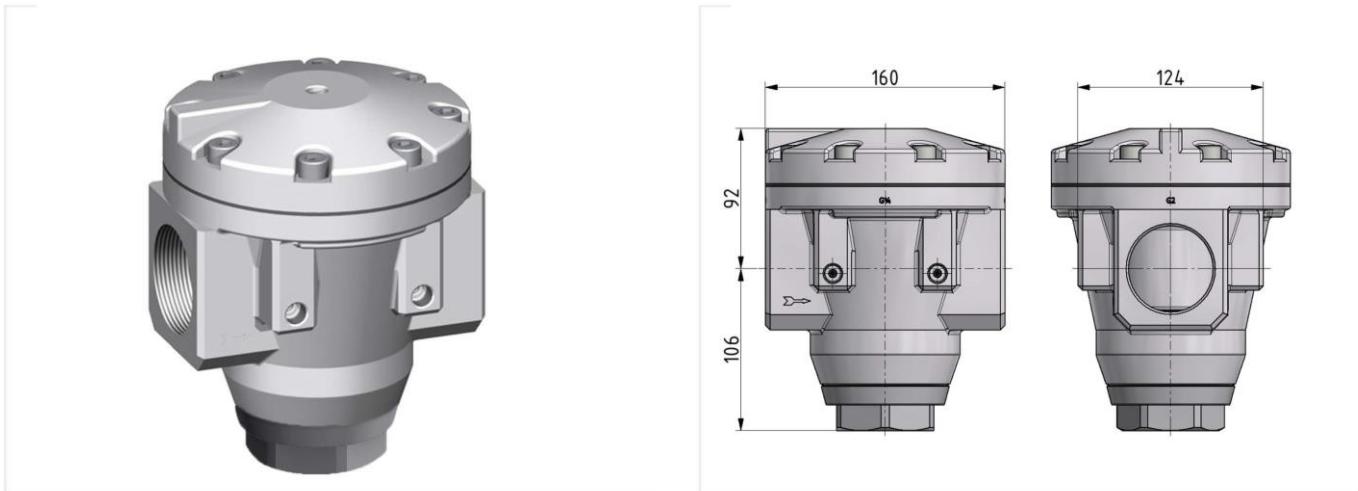

series	port size	flow rate	adjustment range P2 max.	weight
Standard	G 2	50000 l/min	16 bar	5.539 kg

technical data

- **description:** air line regulator with diaphragm and relieving feature, pneumatic pilot-operated (1:1)
- **medium:** compressed air, neutral gases
- **supply pressure P1 max.:** 25 bar
- **medium and ambient temperature:** -10 to 60 °C

Pressure regulators with pneumatic remote control

Art. No. 101257 - Type No. 637.306



flow characteristic

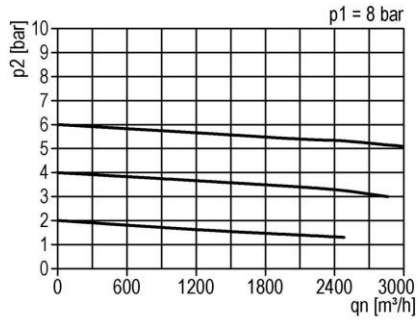

operating conditions

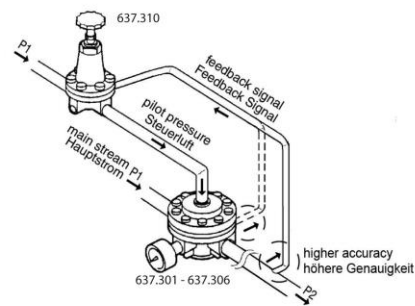

pressure characteristic

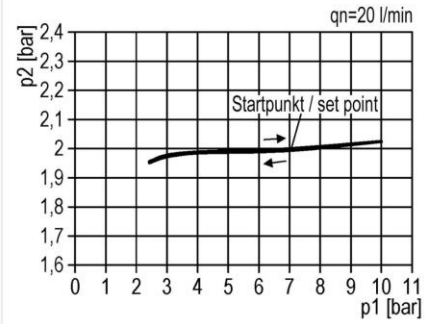

symbol

